

VITO cart Spec sheet



Description and application

The VITO cart is a stainless-steel transport trolley made of high-quality stainless steel (1.4301) and is used for the safe transport of the VITO portable frying oil filter.

Accessories can also be transported safely.

The two shelves are designed for transporting GN 1/1 containers.

The VITO cart is supplied for self-assembly by the user.

The required tools are included in the delivery.



Features

- ♣ Safe, clean and drip-free transport of the VITO portable frying oil filters
- ♣ Push handle and swivel castors allow flexible movement to the place of use
- ♣ Parking brakes keep the trolley securely in place
- ♣ Transport of various items possible thanks to the continuous stop edges
- ♣ Hygienic, made of food-grade stainless steel (1.4301)
- ♣ Optimal size for GN 1/1 containers

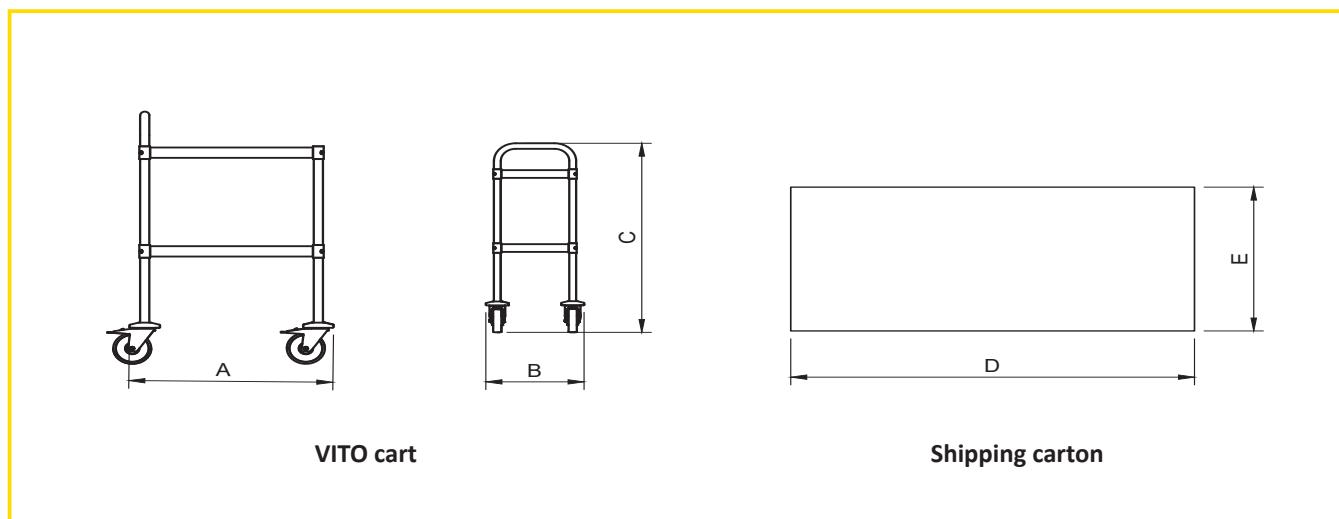

VITO cart

Shipping carton

VITO cart – Technical data:

VITO cart:	Length A	Width B	Height C	Weight	Maximum load
	670 mm	430 mm	1030 mm	12 kg	50 kg
Shipping carton:	Length D	Width E	Depth T	Shipping weight	
	880 mm	375 mm	175 mm	13 kg	

Accessories

- ♣ Assembly tools included in delivery